

HP Designjet 8000s Printer series



From small signs to large banners, this 64-inch printer is the perfect tool for any print or sign shop. Experience a breakthrough price/performance combination with this low-solvent large-format device for a wide range of long-lasting applications.



Print more, pay less

- **Heavy-duty HP printheads and HP supplies for maximum productivity**
Experience high-speed printing with six heavy-duty Piezo printheads that come with 254 nozzles per printhead for a total of 1,524 nozzles. 500 ml, HP 780 ink cartridges are designed to meet your usage needs.
- **Produce striking signs with this in-the-box RIP: Onyx SignEZ v2.0 for HP Designjet**
Providing you with the essential tools to get started, this software RIP is easy to use and navigate, has basic color correction tools, basic nesting and tiling, and support for contour cutting.
- **Minimize your costs and get lasting output on uncoated media**
Count on excellent quality output on a range of low cost, uncoated materials, such as adhesive vinyls, films, banner stocks, papers, and fabrics.
- **Enable long, unattended print runs for improved productivity with optional Take-Up Reel Kit**
This optional accessory enables busy print and sign shop employees to be more productive by maximizing unattended printing with four winding modes: slack/face-in, slack/face-out, tight/face-in, and tight/face-out.

Vivid colors with excellent durability

- **Wow your clients with vivid color output that shines brightly**
Create signs, banners, and large graphics with such vivid color, they radiate success. Sophisticated HP "low-solvent"⁽¹⁾ ink formulations and printhead technology enable a higher concentration of colorants in the inks to produce a wider gamut of rich, saturated color. The result - more vivid color for high impact image quality.
- **HP low-solvent inks - excellent durability without lamination on low-cost, uncoated media**
Designed with the HP 8000s Printer, HP low-solvent ink formulations produce durable prints that resist fading for three years without lamination and are scratch, smear, and crack resistant.⁽²⁾
- **Premium image quality - HP printing materials designed with HP low-solvent inks**
With HP Premium Scrim Banner, HP Universal Scrim Banner, and HP Premium Backlit Film, get premium image quality and high opacity.

A comprehensive HP solution

- **Purchase your large-format printer and the supplies you need from your one-stop shop: HP**
Getting your business up and running couldn't be easier when you choose HP. Purchase the hardware and the supplies you need - including HP ink supplies and HP printing materials - from a single vendor.

At HP, we make it easy for you to grow your business with this comprehensive, scalable solution

- Not only does HP deliver a reliable, top-quality printer, we also provide the optional accessories you need as your business grows to produce multiple signage applications - including a Take-Up Reel Kit, High Speed Dryer, and Air Purifier System - easily and efficiently.
- **Avoid trial and error with customized media profiles**
The HP Designjet 8000s Printer series, its ink supplies, and HP printing materials are designed together. Customized media profiles optimize interaction between HP low-solvent inks, HP printing materials, and the Designjet printer to maximize system performance. Less trial and error makes your job easier and increases productivity.

Safety and support-at HP, your needs come first

- **Have a clean, safe print environment with an integrated air purifier created for HP Designjets**
This printer-connected system uses a sealed, carbon-activated filter and high-powered fan to filter air at a rate consistent with the print speed and the number of volatile organic compounds released during the printing process.
- **HP guidelines help make HP low-solvent ink printing safe, productive, and easy**
Following HP's installation and use guidelines helps you achieve a reliable and productive low-solvent ink printing solution and helps you address environmental, health, and safety questions about printing with HP low-solvent inks.
- **Designed together for HP quality and reliability**
The HP Designjet printing system - printers, low-solvent inks, ink cartridges, printheads, and printing material - is engineered to work with precision and must meet strict HP quality standards. Reliable operation saves you time and improves your productivity.
- **HP offers the cleaning supplies and replacement ink cartridges needed to maintain your system**
HP training and guidelines help you implement environmentally responsible and safe practices for the purchase, installation, operation, handling, and maintenance of HP low-solvent printing supplies.
- **Experience peace of mind, knowing you're covered with HP's award-winning service and support**
HP's customer service and support backs every product with fast, knowledgeable online e-Support available 24/7 at www.hp.com/support, and easy-to-access phone support provided by HP trained agents. Plus, you can enhance your warranty protection with the purchase of affordable HP Care Pack Services.

⁽¹⁾ HP "low-solvent" inks are defined according to what is currently known in the industry as low-solvent inks.
⁽²⁾ Based on internal HP testing under specific test conditions; relative to key competitors.

HP Designjet 8000s Printer series

1. 11. 89 ft²/8 m² per hour at 720 x 720 dpi with eight passes. 110 ft²/10 m² per hour at 540 x 720 dpi with six passes.
2. Up to 64 in/1626 mm wide
3. 500 ml, HP 780 ink cartridges
4. Interactive front panel
5. USB 2.0 Hi-speed connectivity
6. 3 Integrated heaters
7. Easy media-loading
8. Exhaust attachment for efficient removal of volatile organic components
9. Printhead height adjustable to 2 different positions
10. Onyx SignEZ v2.0 for HP Designjet in-the-box
11. Manual cutter
12. Container for maintenance kit

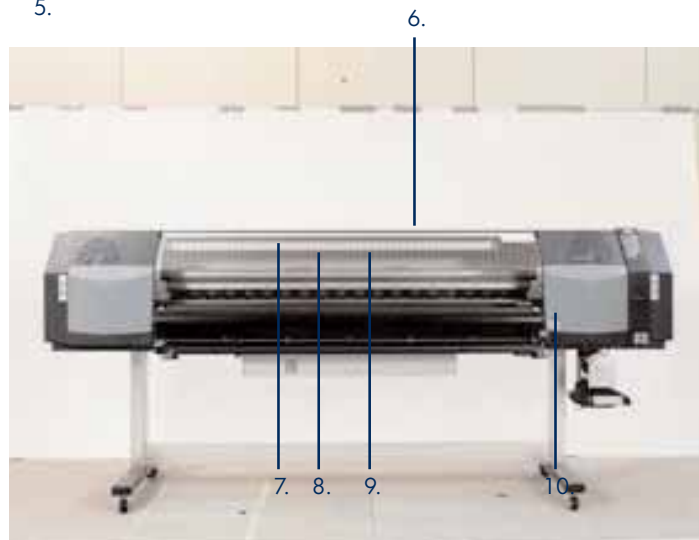
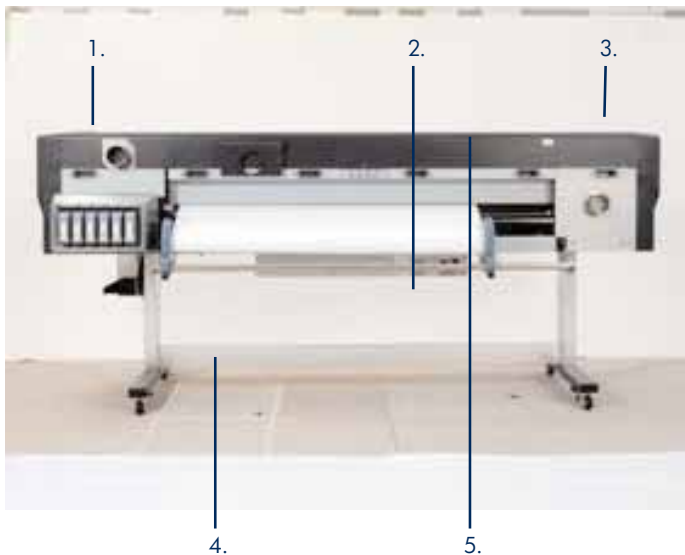

HP DJ 8000s series at a glance

HP Designjet 8000s Printer (EMEA only)

Optional accessories

- HP Air Purifier System 110V/220V
- HP Designjet High Speed Dryer
- ONYX PosterShop 6.5 for HP Designjet
- HP Designjet 8000s/9000s APS filter
- HP Designjet 8000s Take-Up Reel Kit
- HP Designjet 8000s Cutter Blade Kit

HP Designjet 8000sr Printer

Includes

HP Designjet 8000s Printer
ONYX SignEZ v 2.0 for HP Designjet **

** ONYX SignEZ v2.0 for HP Designjet IS NOT available as standalone accessory

Optional accessories

- HP Air Purifier System 110V/220V
- HP Designjet High Speed Dryer
- ONYX PosterShop 6.5 for HP Designjet
- HP Designjet 8000s/9000s APS filter
- HP Designjet 8000s Take-Up Reel Kit
- HP Designjet 8000s Cutter Blade Kit

HP Designjet 8000sf Printer (US and EMEA only)

Includes

HP Designjet 8000s Printer
HP Air Purifier System 110V/220V
ONYX SignEZ v 2.0 for HP Designjet

Optional accessories

- HP Air Purifier System 110V/220V
- HP Designjet High Speed Dryer
- ONYX PosterShop 6.5 for HP Designjet
- HP Designjet 8000s/9000s APS filter
- HP Designjet 8000s Take-Up Reel Kit
- HP Designjet 8000s Cutter Blade Kit

The HP Designjet 8000s Printer series, HP low-solvent ink formulations, ink cartridges, and printing material were all designed, engineered and tested together to ensure uncompromising reliability, image quality, durability, performance and ease of use. To complete the total printing solution, HP offers the following accessories:

HP Designjet Air Purifier System

Put your confidence in HP. Add this air purifier system - specially designed for HP low-solvent inks - to your HP Designjet printer for highly efficient air filtration.

Count on HP for a clean, safe* print environment

- **Highly effective carbon filter removes hazardous substances released from solvent inks**

The air purifier system developed for the HP Designjet 8000s Printer series uses carbon filters to extract from the air volatile organic compounds released during the printing process. The system is designed to filter air at rates consistent with the print speed and the number of compounds released during printing. The HP Designjet 9000s Air Purifier System can also be used with the HP Designjet 8000s Printer series.

- **Return cleaned air to the working area or divert it outside**

This air purification system is equipped with a standard sealing device, and collected pollutants are led automatically through the filter. Direct cleaned air back into the working area through an outlet spigot or divert it outside through an attached hose.

Easily operate with front-panel display unit

- **Access air purification system data through a front-panel display unit**

Unlike some air purification systems, this system has a front-panel display unit that allows you to access certain data, such as run-on time to automatically stop purifier operation a certain amount of time after the printer stops, by entering a pass code. The display panel also houses the controls for starting and stopping operation, and changing the fan speed and filtering power. When it's time to change the filter, you'll be notified through the display panel.

- **Easily replace the filter through the front door on the system**

The front door of the air purification system opens safely and easily for quick filter replacement. A notification on the front-panel me to change the filter.



* When used appropriately, according to the product's guidelines.

HP Designjet High Speed Dryer

Add this high-speed dryer to your HP Designjet 8000s printer and accelerate drying time. Control temperature, fan airflow, and the timer from the front panel. Count on the stable stand and heating and blowing technology for safe operation.

Improve productivity - dryer reduces drying time

- **Dry prints as quickly as the automatic take-up reel can roll them up**
When you use the automatic take-up reel to roll up printed output, you must also use a dryer to keep the ink from transferring from one part of the print to another or from print to print. With the high-speed dryer and take-up reel, you can complete jobs at a rate of up to 322 ft²/hour (98 m²/hour). The integrated dryer and take-up reel enable unattended print runs.

Easily operate high-speed dryer

- **Completely dry prints with user-adjustable heater and blower unit**

Adjust the high-speed dryer to meet your drying needs. Use variable controls on top of the dryer unit to set the heater temperature between 98 and 136 degrees Fahrenheit (between 36.5 and 57.5 degrees Celsius) and to adjust the fan airflow.

- **Dryer's off timer allows unattended drying for up to 12 hours**
Dry print jobs even when you can't be there. Set the dryer's off timer from 1 to 12 hours to print unattended runs.

Count on a dryer that was designed for safety

- **Built for high-volume, commercial print environments**
Made with a brushed aluminum finish, the high-speed dryer's tough exterior stands up to the rigors of sign-making operations.

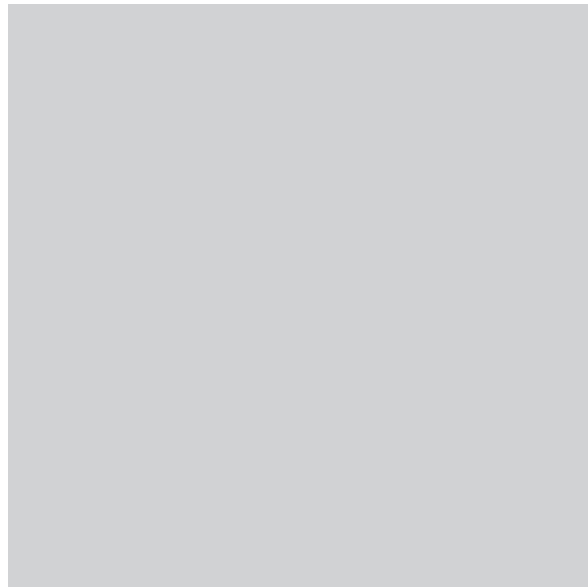

HP Designjet 8000s Take-up Reel Kit

Does your shop have more to print than it can keep up with? With the HP Designjet 8000s Take-up Reel Kit, busy print and sign shop employees can make the most of their time by printing continuous, unattended runs - even overnight - and on long printing materials. The sturdy reel supports four positions-slack/face-in, slack/face-out, tight/face-in, and tight/face-out. Shops better meet client deadlines by maximizing unattended printing and efficiently collecting prints for finishing.

Onyx PosterShop 6.5 for HP Designjet

Use this Onyx PosterShop RIP, created specially for HP Designjets, to print job after job of the best colors your printer can produce. Efficiently manage jobs and handle production with job preflight and printer queue tools.

Print the colors your customers expect

- **HP printer drivers developed for HP Designjets ensure access to all the printer's capabilities**

Automatically install the external software RIP program and HP custom-developed printer drivers in one easy step. Made specifically for HP Designjets, these printer drivers are high-quality, reliable printing solutions that ensure you can take advantage of all the printer's capabilities.

- **Make color changes - to precise spots or entire images - with intuitive color correction tools**

Quickly and easily make color changes - to precise spots or entire images -with intuitive color correction tools, without leaving the program. Change the brightness, saturation, and contrast for the entire image, or adjust highlights, mid-tones, and shadows. Even fine-tune select areas to achieve the perfect look. All without affecting the original file.

- **Have CMYK colors pop with PosterColor color rendering technology by Onyx**

A well-known fact among print operators is that applying ICC profiles to CMYK print jobs dulls the colors. PosterColor color rendering technology by Onyx reverses this affect - achieving brilliant, saturated colors while maintaining gray balance when ICC profiles are applied.

- **Match colors as closely as possible to the Pantone Color Library**

This RIP includes a fully licensed Pantone Color Library, which makes spot color matching easy because more accurate Pantone spot color matching happens automatically during processing. The RIP recognizes Pantone-named colors in PostScript or PDF files and matches the colors as closely as possible.

Print and customize jobs quickly and easily

- **Modify jobs and see final layout on your screen before printing with easy-to-use preflight controls**

Avoid unexpected and costly results at the final output stage.

Use the RIP's easy-to-navigate and easy-to-use preflight controls to ensure that all the necessary components-fonts, images, color profiles, etc.-are correct and in the right location. See the final file layout on your screen before it prints. If necessary, adapt the file. Scale, crop, and rotate images. Apply custom tiling. And make color corrections. All with controls that are at your fingertips.

- **Print directly from your creative applications or from Hot Folders that specify job properties**

This RIP supports up to two printers with multiple Hot Folders.

Hot Folders are used to set up job properties. Either print directly from your creative applications or drag and drop jobs into the appropriate Hot Folder. When the program detects an available printer that matches the job properties, printing begins automatically. Using Hot Folders allows you to control job workflow and streamline job management.

- **Manage your print jobs remotely with a web browser through a web portal**

Web access to the RIP makes print job management easy.

Manage your print jobs from any computer on your network that has a web browser. You can even submit jobs through the web portal.



HP Designjet 8000s Printer series

Technical specifications

Print speed	Up to 100 A1/D pages per hour ¹ , 93 m ² /hr, 1000 f2/hr ²
Resolution, maximum	Up to 2400 x 1200
Line accuracy	+/- 0.1%
Print margins	
Top	0.2 in/5 mm (Small); 0.45 in/11.5 mm (Normal); 2.1 in/55 mm (Extended)
Bottom	0.2 in/5 mm (Small & Normal); 2.1 in/55 mm (Extended)
Side	0.2 in/5 mm (Small & Normal); 0.6 in /15 mm (Extended)
Printer media	
Thickness (by paper path)	All paths: up to 0.157 in/0.4 mm
Weight (by paper path)	All paths: 0.11 to 0.72 lb/50 to 328 g/m ²
Size	Rolls up to 42 in/1067 mm wide
Printing	
Technology	HP Thermal Inkjet
Technology resolution	HP Color Layering technology, HP PhotoREt III
Print cartridge colors	Black, cyan, magenta, yellow
Ink types	Black pigmented, CMY dye based
Ink drop	5 pl color, 15 pl black
Scan³	
Speed	Color (200 dpi): 3in/sec (76mm/sec);
Resolution	Best Mode: black&white 300 x 300 dpi, color 300 x 300 dpi Normal Mode: black&white 200 x 200 dpi, color 200 x 200 dpi 42in/1067mm 0.6 in /15 mm
Max. Scan Width	
Max. Scan Thickness	
Copying	
Copy Resolution	300 x 300 dpi
Reduction/Enlargement	1 to 10,000%
Maximum Copies	99
Copier Settings	Type of original, image crop and align preview, lightness, saturation and RGB controls, sharpen/blur, mirror copy, enlarge/reduce, panning, tiling, nesting, and accounting
Memory	256 MB (upgradeable to 512 MB), 40 GB hard disk
Media Handling	
Printers	Two automatic rolls, automatic roll-switching, automatic cutter
Scanner ³	Straightthrough scan paper path for sheet and cardboard originals, output basket
Media Types	
Printers	Paper (plain, inkjet, coated, heavyweight coated, super heavyweight coated, semi-gloss, glossy, translucent bond, natural tracing, photo, vellum), film.
Scanner ³	Non-abrasive paper, vellum, mylar, sepia, blueprints, plastic, film, plastic laminate, foam board, cardboard, no plywood, no stone plates, no metal plates nor abrasive dirty, rough, sharp edged, metal clamped, burned surfaces
Stacker	Paper (plain, inkjet, coated, heavyweight coated, super heavyweight coated, semi-gloss, translucent bond, natural tracing, photo, vellum) ⁴
Connectivity	
Interfaces Standard: Printers	1 EIO slot, embedded Jeldirect, Fast Ethernet (10/100 Mbps), FireWire (IEEE 1394a-compliant)
Interfaces Standard: Scanner ³	1 Fast Ethernet 10/100 Base-TX
Interfaces Optional	HP Jeldirect 620n LAN Card, HP Jeldirect 40d Gigabit Print Server for the HP Designjet 4000 Printer series, HP Designjet 4000 Printer series Hi-speed USB 2.0 card
Drivers (included)	HP-GL/2, HP-RTL, Windows drivers, PS Windows drivers (HP Designjet 4500ps & HP Designjet 4500mpf only), ADI driver for AutoCAD R14, support for AutoCAD 200x, support for Citrix MetaFrame environments, PS driver for Mac OS X v 10.2.8, 10.3, 10.4
Print languages (standard)	
HP Designjet 4500 Printer	HP-GL/2, HP-RTL, TIFF, JPEG, CALS-G4
HP Designjet 4500ps Printer & HP Designjet 4500mpf	Adobe PostScript Level 3, Adobe PDF 1.5, HP-GL/2, HP-RTL, TIFF, JPEG, CALS-G4
Dimensions (h x d x w)	
Maximum Printer	76 x 31.5 x 53.2 in /1930 x 800 x 1350 mm
Maximum Scanner ³	70.8 x 40.2 x 54.3 in/1800 x 1020 x 1380 mm
Shipping printer	83.9 x 30.5 x 52 in (EMEA), 83.9 x 30.5 x 74.4 in (CA, LAR, NA, AP) / 2130 x 775 x 1320 mm (EMEA), 2130 x 775 x 1890 mm (CA, LAR, NA, AP)
Shipping scanner ³	75.2 x 27.2 x 28.7 in /1910 x 690 x 730 mm
Weight	
Printers	408 lb/185 kg
Scanner ³	209.5 lb/95 kg
	501.1 lb (EMEA), 600.3 lb (CA, LAR, NA, AP) /227.3 kg (EMEA), 272.3 kg (CA, LAR, NA, AP) Shipping, scanner3: 321.9 lb /76 kg
What's in the box	
HP Designjet 4500/4500ps	HP Designjet 4500 Printer, stand and basket assembly, Roll Module, Setup Poster, Documentation & Drivers CD, Quick Reference Guide and holder, media sample, maintenance kit, power cord, 3" spindle adaptor (4), printhead (8), printhead cleaners (8), ink cartridges (4), ink cartridge insert, ink printhead insert, Customer Service Guide
HP Designjet 4500mpf	All the features mentioned above, plus HP Designjet 4500 Scanner, Stand and basket assembly, Graphical Display, Keyboard, Power cables, FireWire cables (X2), Media guides (X2), Maintenance sheet, System recovery DVD, Maintenance kit, Plastic dust cover, Scanner Setup Poster, Scanner Quick Reference Guide, Customer service guide

¹ Mechanical printing time. Printed in fast mode on HP Bright White Inkjet paper (Bond).
Speed indicated is maximum printer speed.
² Multi-copy printing. Printed in Fast mode on HP Bright Inkjet paper (Bond). Speed indicated is maximum printer speed.
³ HP Designjet 4500mpf only.
⁴ The HP Designjet 4500 Stacker series does not support films, including HP Clear Film and HP Matte Film or other media with long drying time

Environmental ranges

Operating temperature	41 to 104° F/5 to 40° C
Recommended operating temperature	59 to 86° F/15 to 30° C
Storage temperature	-4 to 131° F/20 to 55° C
Operating humidity	20 to 80% RH
Recommended humidity	25 to 75% RH

Acoustic

Sound pressure, active	46 dB(A)
Sound pressure, standby	41 dB(A)
Sound power, active	6.3 B(A)
Sound power, standby	5.8 B(A)

Power consumption

Maximum	500 watts, 800 watts ³
---------	-----------------------------------

Power requirements

Printers	Input voltage 100 to 127 VAC (+/- 10%), 6 amp; 220 to 240 VAC (+/- 10%), 3 amp; 50/60 Hz (+/- 3 Hz); auto range
Scanner	100 to 240 VAC (+/- 10%), auto range, 50/60 Hz, 5 amp maximum ³

Power certification

Safety certification	Compliant with IEC 60950, including EU LVD and EN60950, CSA-certified for US and Canada, Mexico NYCE, Argentina IRAM, Singapore PSB, Russia VNIIS, NEMKO, China CCC, Taiwan BSMI
Electromagnetic compatibility	Compliant with Class A requirements, including EU (EMC Directive), US (FCC rules), Canada (DoC), Australia (ACA), New Zealand (MoC), Japan (VCCI), Korea (MIC), Taiwan (BSMI) Yes, No ³
Energy Star compliant	One-year next-business-day on-site

Warranty

Care packs

HP Designjet 4500 and 4500ps	UD631A/E: 3 year Next-Day Onsite - onsite next day support UD634A/E: 3 year 9x5 Same-Day Onsite - onsite support in 4 hours UD637A/E: 3 year 13x5 Same-Day Onsite - onsite support in 4 hours UD640PA/PE: Next day onsite - 1-Year post warranty UD641PA/PE: 9x5 Same-day onsite - 1-Year post warranty UD642PA/PE: 13x5 Same-day onsite - 1-Year post warranty
------------------------------	--

HP Designjet 4500mpf

UD644A/E: 3 year Next-Day Onsite - onsite next day support UD647A/E: 3 year 9x5 Same-Day Onsite - onsite support in 4 hours UD894A/E: 3 year 13x5 Same-Day Onsite - onsite support in 4 hours UD897PA/PE: Next-day onsite - 1-Year post warranty UD898PA/PE: 9x5 Same-day onsite - 1-Year post warranty UD899PA/PE: 13x5 Same-day onsite - 1-Year post warranty
--

Energy Star® Energy Star logo® are US registered marks of the United States Environmental Protection Agency. Microsoft and Windows are U.S. registered trademarks of Microsoft Corporation. Adobe® and Adobe®PostScript® 3™ are trademarks of Adobe Systems Incorporated. AutoCAD is a U.S. trademark of Autodesk, Inc.
© 2004 Hewlett-Packard Development Company, L.P. The information contained herein is subject to change without notice. The only warranties for HP products and services are set forth in the express warranty statements accompanying such products and services. Nothing herein should be construed as constituting an additional warranty. HP shall not be liable for technical or editorial errors or omissions contained herein.



Ordering information

Product
Q1271A HP Designjet 4500 Printer
Q1272A HP Designjet 4500ps Printer
Q1276A HP Designjet 4500mpf

Accessories

Q5676A HP Designjet 4500 - 42 inch Roll Feed Spindle
Q5690A HP Designjet 4000 series High Speed USB 2.0 Card
Q5675A HP Designjet 4000 series 256 MB Memory Upgrade
Q5677A HP Designjet 4500 Stacker
J7934A HP Jeldirect 620n LAN card
Q5679A HP Jeldirect 40d Gigabit Print Server for the Designjet 4500 series
Q1277A HP Designjet 4500 Scanner (comes as standard with HP Designjet 4500mpf)

Ink supplies

C5094A HP 90 Black Printhead and Cleaner
C5055A HP 90 Cyan Printhead and Cleaner
C5056A HP 90 Magenta Printhead and Cleaner
C5057A HP 90 Yellow Printhead and Cleaner
C5058A HP 90 Black Ink Cartridge, 400 ml
C5059A HP 90 Black Ink Cartridge, 775 ml
C5060A HP 90 Cyan Ink Cartridge, 225 ml
C5061A HP 90 Cyan Ink Cartridge, 400 ml
C5062A HP 90 Magenta Ink Cartridge, 225 ml
C5063A HP 90 Magenta Ink Cartridge, 400 ml
C5064A HP 90 Yellow Ink Cartridge, 225 ml
C5065A HP 90 Yellow Ink Cartridge, 400 ml
C5078A HP Black Value Pack (Printhead & Cleaner + 400 ml Ink Cartridge)
C5079A HP Cyan Value Pack (Printhead & Cleaner + 400 ml Ink Cartridge)
C5080A HP Magenta Value Pack (Printhead & Cleaner + 400 ml Ink Cartridge)
C5081A HP Yellow Value Pack (Printhead & Cleaner + 400 ml Ink Cartridge)
C5082A HP 90 Black 3-Ink Cartridge Multipack (3 x 400 ml)
C5083A HP 90 Cyan 3-Ink Cartridge Multipack (3 x 400 ml)
C5084A HP 90 Magenta 3-Ink Cartridge Multipack (3 x 400 ml)
C5085A HP 90 Yellow 3-Ink Cartridge Multipack (3 x 400 ml)
C5095A HP 90 Black 3-Ink Cartridge Multipack (3 x 400 ml)
C5096A HP 90 Black Printhead Cleaner

Media supplies

C6810A HP Bright White Inkjet Bond Paper (36 in x 300 ft/914 mm x 91.4 m)
S1642B HP Matte Film (36 in x 125 ft/914 mm x 38 m)
C3868A HP Natural Tracing Paper (36 in x 150 ft/914 mm x 45.7 m)
C3859A HP Translucent Bond (36 in x 150 ft/914 mm x 45.7 m) NA, LA, AP
C6980A HP Coated Paper (36 in x 300 ft/914 mm x 91.4 m)
C6030C HP Heavyweight Coated Paper (36 in x 100 ft/914 mm x 30.48 m)
Q1956A HP Heavyweight Coated Paper (42 in x 225 ft/1067 mm x 68.58 m) NA & EMEA
Q6576A HP Universal Instant Dry Photo Glass (42 in x 100 ft/1067 mm x 30.48 m)
Q6581A HP Universal Instant Dry Photo Semi-Gloss (42 in x 100 ft/1067 mm x 30.48 m)
Q8004A HP Universal Inkjet Bond Paper (A1, 594 mm x 91.5 m) EMEA & JP
Q8002A HP Universal Inkjet Bond Paper (36 in x 500 ft/914 mm x 152.4m)
Q8005A HP Universal Inkjet Bond Paper (A0, 841 mm x 91.5 m) EMEA & JP
Q1392A HP Universal Inkjet Bond Paper (42 in x 150 ft/1067 mm x 45.7 m) NA, EMEA, AP
Q1406A HP Universal Coated Paper (42 in x 150 ft/1067 mm x 45.7 m)
Q1414A HP Universal Heavyweight Coated Paper (42 in x 100 ft/1067 mm x 30.48 m) NA, EMEA, AP
Q6627A HP Super Heavyweight Plus Matte Paper (36 in x 100 ft/914 mm x 30.58 m) NA, EMEA, AP
Q6628A HP Super Heavyweight Plus Matte Paper (42 in x 100 ft/1067 mm x 30.48 m) NA, EMEA, AP

For more information, visit our website at
www.hp.com/go/designjet4500

